

XENYX 1002B

Premium 10-Input 2-Bus Mixer with XENYX Preamps, British EQs and Optional Battery Operation

- Premium ultra-low noise analog mixer with optional battery operation
- 2 state-of-the-art XENYX Mic Preamps comparable to stand-alone boutique preamps
- Neo-classic "British" 3-band EQs for warm and musical sound
- Optional battery operation (with 9 V alkaline batteries) allows for mobile operation
- 4 balanced, high-headroom stereo inputs with 3 additional mic inputs
- One FX send and one Monitor send per channel for external FX devices and monitor applications
- Clip LEDs on all channels and dedicated inserts on all mono channels
- Main output plus separate Phones and CD/Tape outputs
- Switchable phantom power for condenser microphones
- Long-wearing 60-mm logarithmic-taper master fader and sealed rotary controls
- External power supply for noise-free audio and superior transient response
- High-quality components and exceptionally rugged construction ensure long life
- Conceived and designed by BEHRINGER Germany



State-of-the-Art Goes Portable

Whether you plug it into the wall or power it via 9 V batteries, the XENYX 1002B comes equipped with many of the features you've come to expect from our larger mixers, including XENYX mic preamps for amazing sound quality, phantom power for use with professional-grade condenser mics, 2-Track inputs and outputs, and 60 mm faders. The four stereo channels accept left/right or mono 1/4" TRS/TR inputs, and three of them also accommodate microphones (with separate Trim controls). The compact XENYX 1002B mixer also features our highly musical 3-band British EQ, plus an FX and monitor send for each channel, making it a must-have for any audio toolkit.

Superior mic preamps

The XENYX 1002B represents a significant milestone in the development of mixer technology. Equipped with our premium XENYX mic preamps, it can easily hold its own against the most expensive stand-alone mic preamps, both in terms of sound quality and available headroom. XENYX preamps offer a staggering 130 dB of dynamic range, with a bandwidth that extends from below 10 Hz to well above 200 kHz. XENYX mic pres provide such transparent, crystal-clear performance you just might think someone upgraded your mics.

Continued on next page



XENYX 1002B

Sublimely musical British EQ

The British consoles of the 1960s and '70s changed the sound of rock and roll—without them the British Invasion might not have happened. Those legendary mixing desks soon became the envy of engineers and producers all over the world. The 3-band EQ on the XENYX 1002B mixer is based on that very same circuitry, allowing you to imbue signals with incredible warmth and detailed musical character. Even when applied generously, these equalizers exhibit sweet forgiveness and superb audio quality.

Applications and value

Don't let the small footprint fool you—the XENYX 1002B is built to the same exacting standards as our larger-format XENYX mixers and is housed in an equally rugged steel chassis. It is the ideal choice for keyboardists who need to mix down multiple instruments or sound modules for live or recording applications. Singers who perform with backing tracks, as well as instrumentalists/singers (acoustic guitar or piano bar, for example) find the XENYX 1002B indispensable for patching into "house" systems.

Field Operation

Its compact size and flexible input scheme also make it the natural choice of sports announcers for calling play-by-play game action. Likewise, radio and TV reporters especially like the XENYX 1002B for its ease-of-use, remarkable fidelity and rugged reliability. And the 9V battery option allows newscasters and correspondents to use the 1002B in remote locations where power is hard to come by. (Two 9V alkaline batteries are required for normal operation, three for phantom power).

From its state-of-the-art XENYX mic preamps to its highly musical British-style EQ and user-friendly layout, the XENYX 1002B is the solid leader for value and sonic integrity in its class.

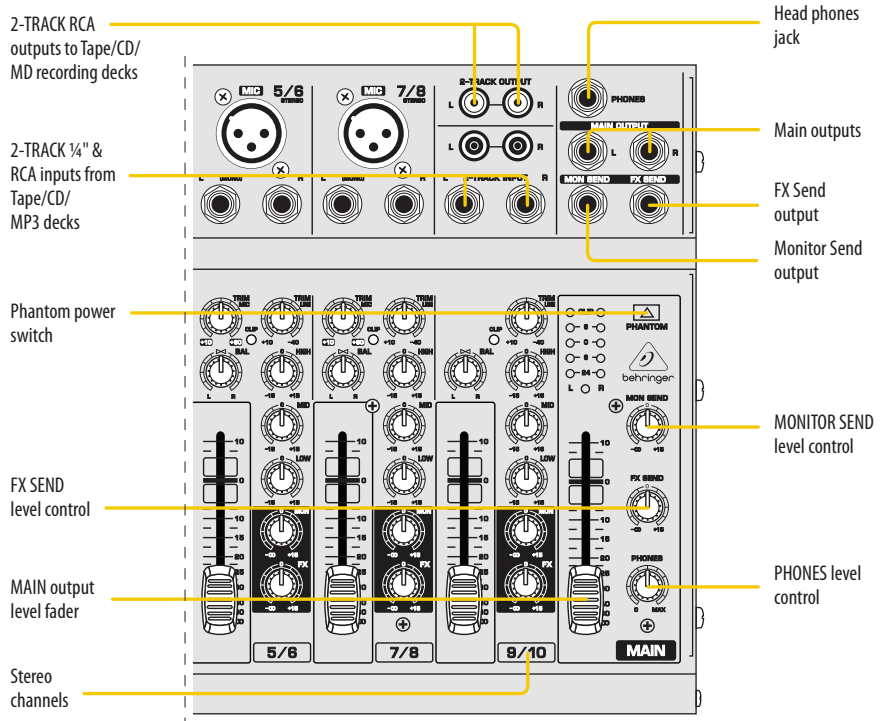
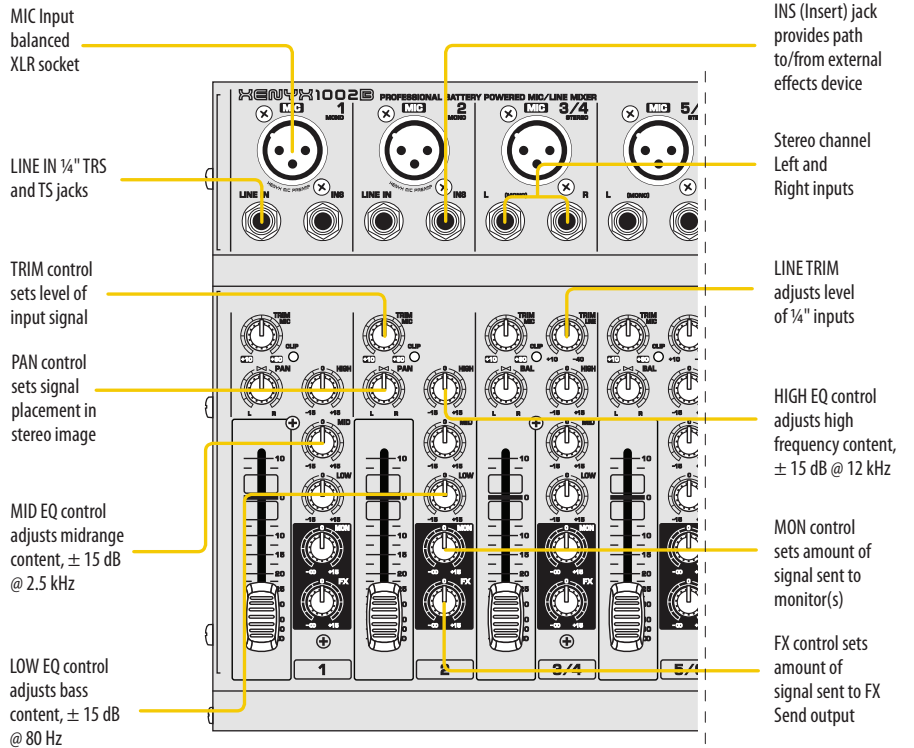

XENYX 1002B

Field Recording Setup

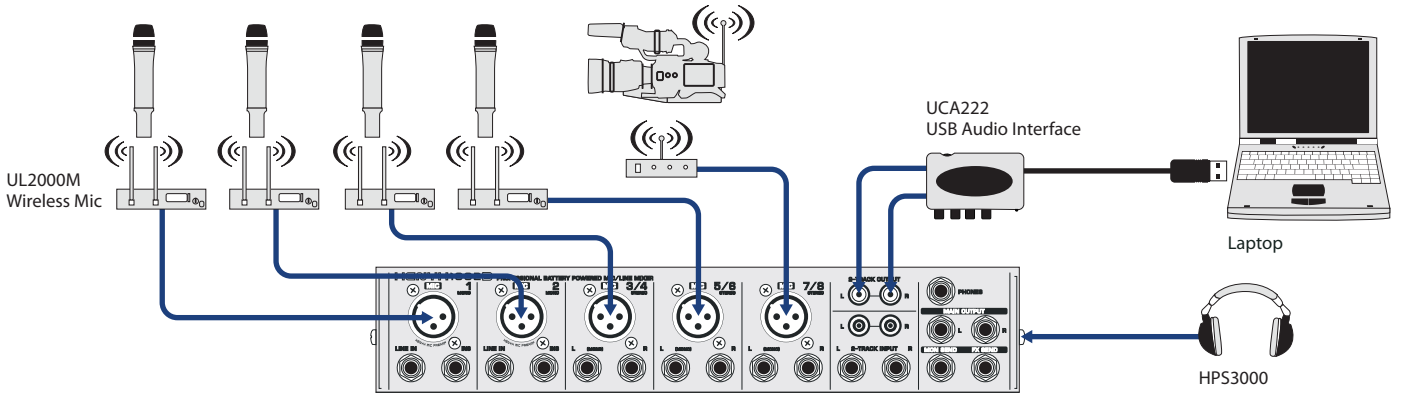

Recording Setup

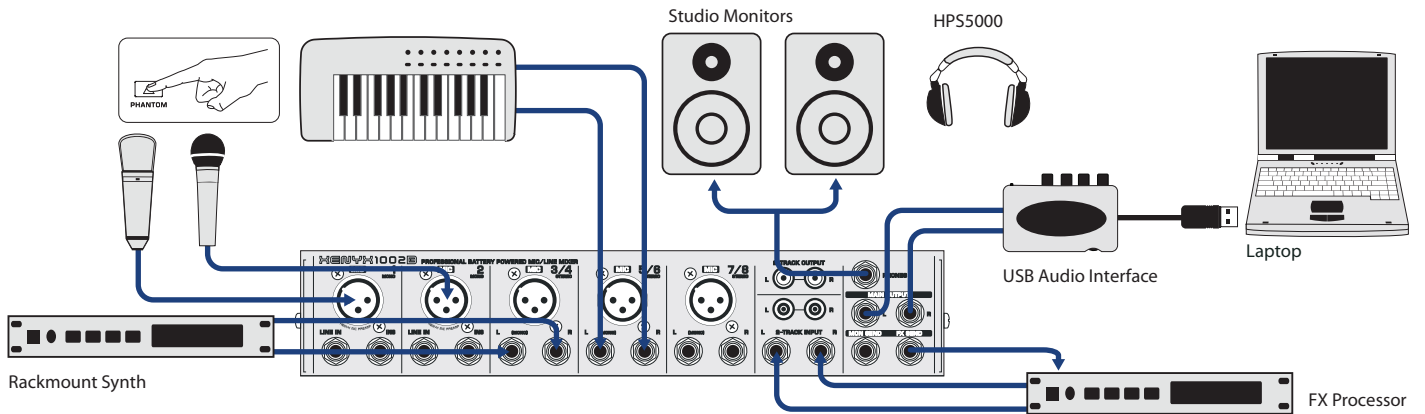

Live Performance

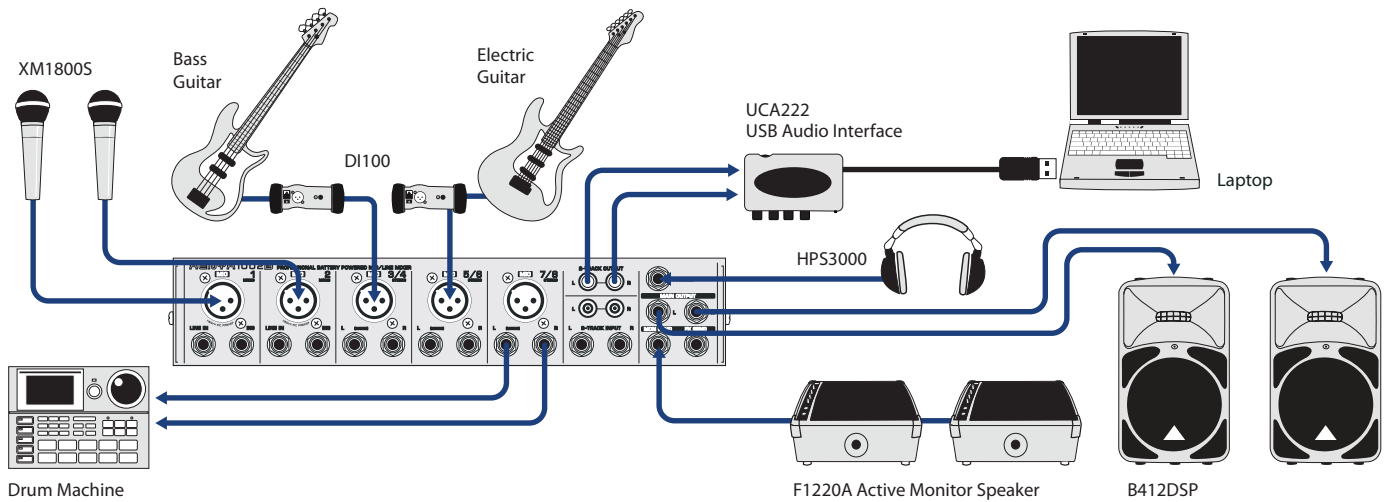

XENYX 1002^B

Specifications

Input Channels 1 & 2

Mic input	electronically balanced, discrete input configuration
Frequency response	10 Hz to 200 kHz
Gain range	+14 dB to +60 dB
SNR	120 dB E.I.N.
Line input	electronically balanced
Frequency response	10 Hz to 130 kHz
Gain range	-6 dB to +38 dB
SNR	95 dB E.I.N.

Stereo Channels 3/4 - 7/8 & 9/10

Frequency response	10 Hz to 70 kHz
Gain range	Line: -∞ to +15 dB Mic: +13 to +60 dB
SNR	Line: 96 dB / Mic: 104 dB E.I.N.

Equalization

LOW	50 Hz, +/- 15 dB
MID	700 Hz, +/- 15 dB
HI	10 kHz, +/- 15 dB

Main Mix

Main Outputs	+28 dBu balanced, +22 dBu unbalanced
Mon Send	+22 dBu unbalanced
FX Send	+22 dBu unbalanced
Tape Out	+22 dBu unbalanced
Phones Output	+15 dBu / 150 Ω

Power Supply

Mains voltage	
USA/Canada Power Supply	120 V~, 60 Hz, MXUL4
U.K./Australia Power Supply	240 V~, 50 Hz, MXUK4
Europe Power Supply	230 V~, 50 Hz, MXEU4
Japan Power Supply	100 V~, 50 - 60 Hz, MXJP4
Battery life (with Duracell Alkaline Type MN1604/580 mAh)	approx. 4 h

Physical

Dimensions (H x W x D)	approx. 2.875 x 11.75 x 8.5" approx. 73 x 298 x 216 mm
Weight	approx. 6.1 lbs/ approx. 2.77 kg

Please note these specifications are preliminary and conceptual in nature, and as such are subject to change as product development progresses. This information is supplied for market research purposes only and is not to be made public in any manner. This document is solely the property of The MUSIC Group, or one of its subsidiaries, and must be surrendered upon request of the owner.

For service, support or more information contact the BEHRINGER location nearest you:

Europe
MUSIC Group Services UK
Tel: +44 156 273 2290
Email: CARE@music-group.com

USA/Canada
MUSIC Group Services NV Inc.
Tel: +1 702 800 8290
Email: CARE@music-group.com

Japan
MUSIC Group Services JP K.K.
Tel: +81 3 6231 0454
Email: CARE@music-group.com

Technical specifications and appearances are subject to change without notice and accuracy is not guaranteed. BEHRINGER is part of the MUSIC Group (music-group.com). All trademarks are the property of their respective owners. MUSIC Group accepts no liability for any loss which may be suffered by any person who relies either wholly or in part upon any description, photograph or statement contained herein. Colors and specifications may vary from actual product. MUSIC Group products are sold through authorized fulfillers and resellers only. Fulfillers and resellers are not agents of MUSIC Group and have absolutely no authority to bind MUSIC Group by any express or implied undertaking or representation. This manual is copyrighted. No part of this manual may be reproduced or transmitted in any form or by any means, electronic or mechanical, including photocopying and recording of any kind, for any purpose, without the express written permission of MUSIC Group IP Ltd. ALL RIGHTS RESERVED. © 2012 MUSIC Group IP Ltd. Trident Chambers, Wickhams Cay, P.O. Box 146, Road Town, Tortola, British Virgin Islands. 985-10000-00392